

CUBE-R™

3D SCANNING COORDINATE MEASURING MACHINE (CMM)



R-Series AUTOMATED INSPECTION SOLUTION

CUBE-R is a fast, reliable, and efficient complete turnkey solution for automated quality control applications. It features the MetraSCAN-R™, a powerful robot-mounted optical 3D scanner that can be integrated into factory automation systems without compromising on accuracy. It is the perfect alternative to solve any productivity issues caused by bottlenecks at the traditional coordinate measuring machine (CMM). Our 3D scanning CMM enables manufacturing companies to harness the power of optical 3D measurement and industrial automation. It optimizes the production cycle and throughput resulting in better product quality.

CUBE-R: THE FASTEST AND TRULY ACCURATE TURNKEY 3D SCANNING CMM

- C-Track™ optical tracker:** Enhances data accuracy from automated photogrammetry
- Dynamic referencing:** The part and the system can rotate freely at any time during measurement on the integrated turntable
- High productivity:** Performs inspection up to hundreds of parts a day
- Highly accurate in any measurement conditions**
- Fastest 3D scanner on the market**
- Tackles black, multicolor and shiny surfaces**
- Part size range:** Up to 3 m
- Complete turnkey solution:** No integration required, fully enclosed and shop-floor-ready

R-Series AUTOCALIBRATION KIT

Allows the complete and automatic calibration of the C-Track and the MetraSCAN 3D-R. All the tools needed for applications requiring no human involvement.

Automatic field calibration procedure
No accuracy drift over time and continuous operation

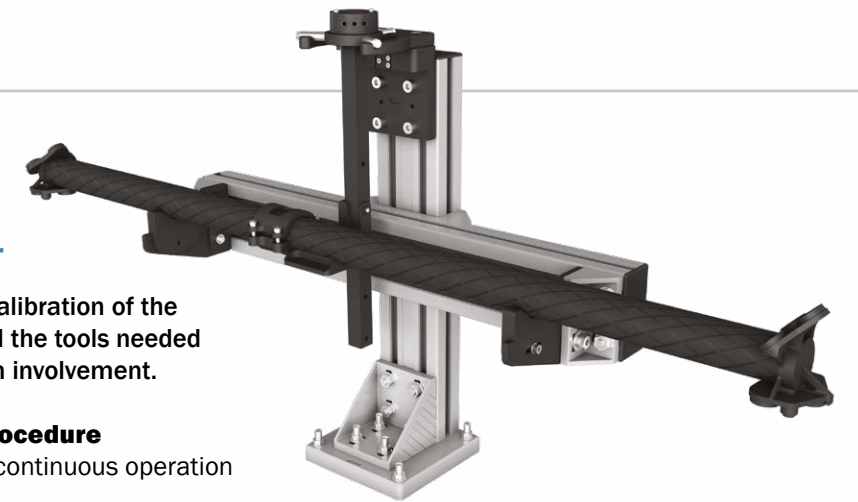

R-Series PRODUCTIVITY STATION

This productivity station addresses applications with high productivity requirements, such as when cycle times need to be reduced and productivity increased.

Multitasking

Allows to carry out data acquisition while simultaneously analyzing previously acquired data enabling continuous operations

Simple user interface

Designed to perform automatic inspection and minimize operator interaction

Robust industrial design

Adapted for shop-floor conditions and environments

VXelements: CREAFORM'S 3D SOFTWARE PLATFORM AND APPLICATION SUITE

3D scanning CMMs are powered by Creaform's VXelements™ 3D software platform and application suite. It combines all the essential tools needed for data acquisition process into a user-friendly, simplified and sleek interface. Its real-time visualization capabilities provide a simple, yet efficient, 3D scanning experience.

For automated applications users can benefit from the productivity interface, which provides real-time performance indicators.

THE MetraSCAN 3D-R IS COMPATIBLE WITH THE FOLLOWING LEADING INSPECTION SOFTWARE

- Metrologic X4 i-Robot
- 3D Systems – Geomagic® Solutions
- InnovMetric Software – PolyWorks®

TECHNICAL SPECIFICATIONS

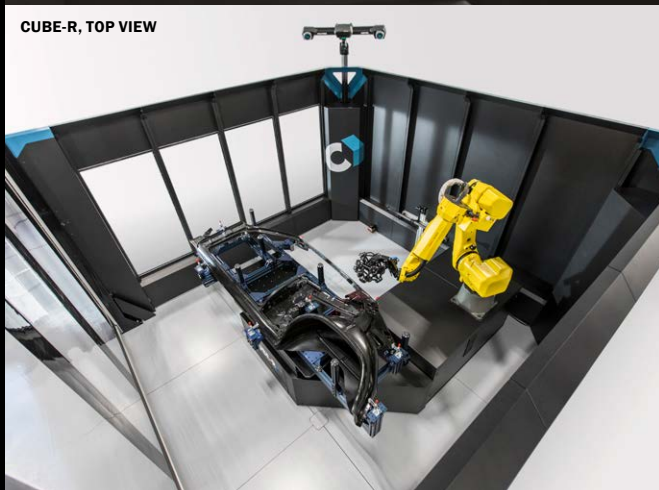
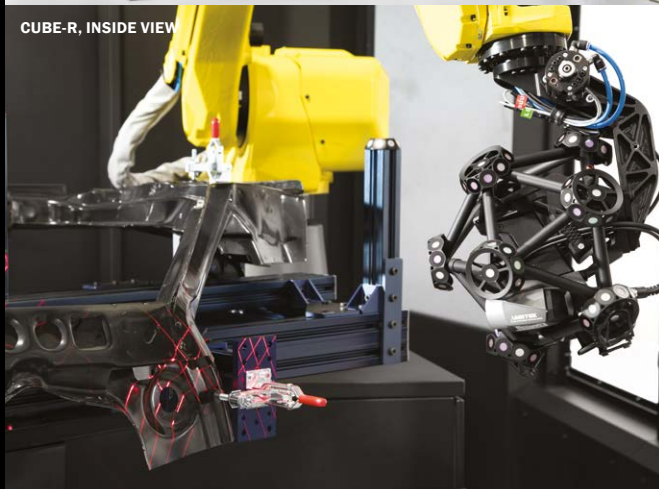

CUBE-R™

DIMENSIONS (LxWxH)	4.1 x 4.1 x 3.1 m
MAX. PART SIZE	Up to 3 x 1.5 m
MAX. PART WEIGHT	Up to 1,500 kg
OPENING WIDTH	3.1 m

MetraSCAN3D™

MetraSCAN 750-R™ | ELITE

ACCURACY ⁽¹⁾	Up to 0.030 mm	
VOLUMETRIC ACCURACY ⁽²⁾	Up to 3 m parts	0.078 mm
RESOLUTION	0.050 mm	
SCANNING AREA	275 x 250 mm	
STANDOFF DISTANCE	300 mm	
DEPTH OF FIELD	200 mm	
LIGHT SOURCE	7 laser crosses (+ 1 extra line)	
LASER CLASS	2M (eye safe)	
MEASUREMENT RATE	480,000 measurements/s	
WEIGHT	Scanner: 4.46 kg Scanner + Calibration bar: 5.70 kg C-Track: 5.7 kg	
INERTIA LIMIT	J6: 0.221 Kg-m ² J6: 2.250 Kgf-cm-s ²	
DIMENSIONS (LxWxH)	289 x 235 x 296 mm	
OPERATING TEMPERATURE RANGE	5–40 °C	
OPERATING HUMIDITY RANGE (non-condensing)	10–90%	
CERTIFICATIONS	EC Compliance (Electromagnetic Compatibility Directive, Low Voltage Directive, Radio Equipment and Telecommunications Equipment), compatible with rechargeable batteries (when applicable), IP50, WEEE	

(1) Typical value for diameter measurement on a calibrated sphere artefact.

(2) Based on the ASME B89.4.22 standard. Performance is assessed with traceable length artefacts by measuring these at different locations and orientations within the working volume of the C-Track (value = maximum deviation).

CREAFORM

AMETEK GmbH
Division Creafom Deutschland
 Meisenweg 37
 D - 70771 Leinfelden-Echterdingen
 T. + 49.711.1856.8030 | F. + 49.711.1856.8099
creafom.info.germany@ametek.com | creafom3d.com

AMETEK®
 ULTRA PRECISION TECHNOLOGIES

Authorized Distributor

CUBE-R, MetraSCAN 3D-R, MetraSCAN 750-R | ELITE, C-Track, Vxelements and their respective logos are trademarks of Creafom Inc.
 © Creafom Inc. 2019. All rights reserved. V1