

PanelProfiler

Board Thickness Measurement System

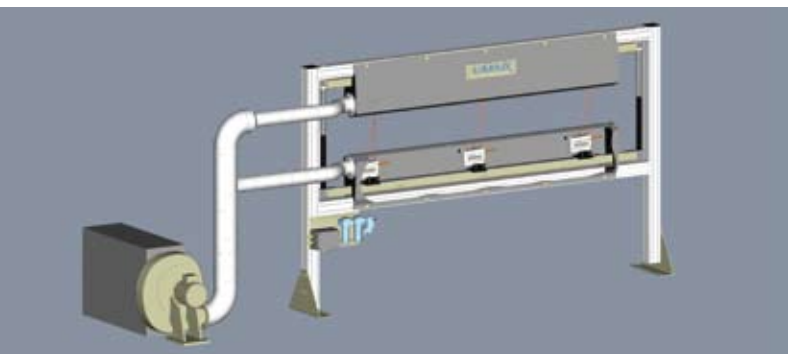

- *High accuracy at all speeds*
- *Non-contact – low maintenance*
- *No marking of surface*
- *Measures thin and soft panels*
- *Increased yield - quick pay back*

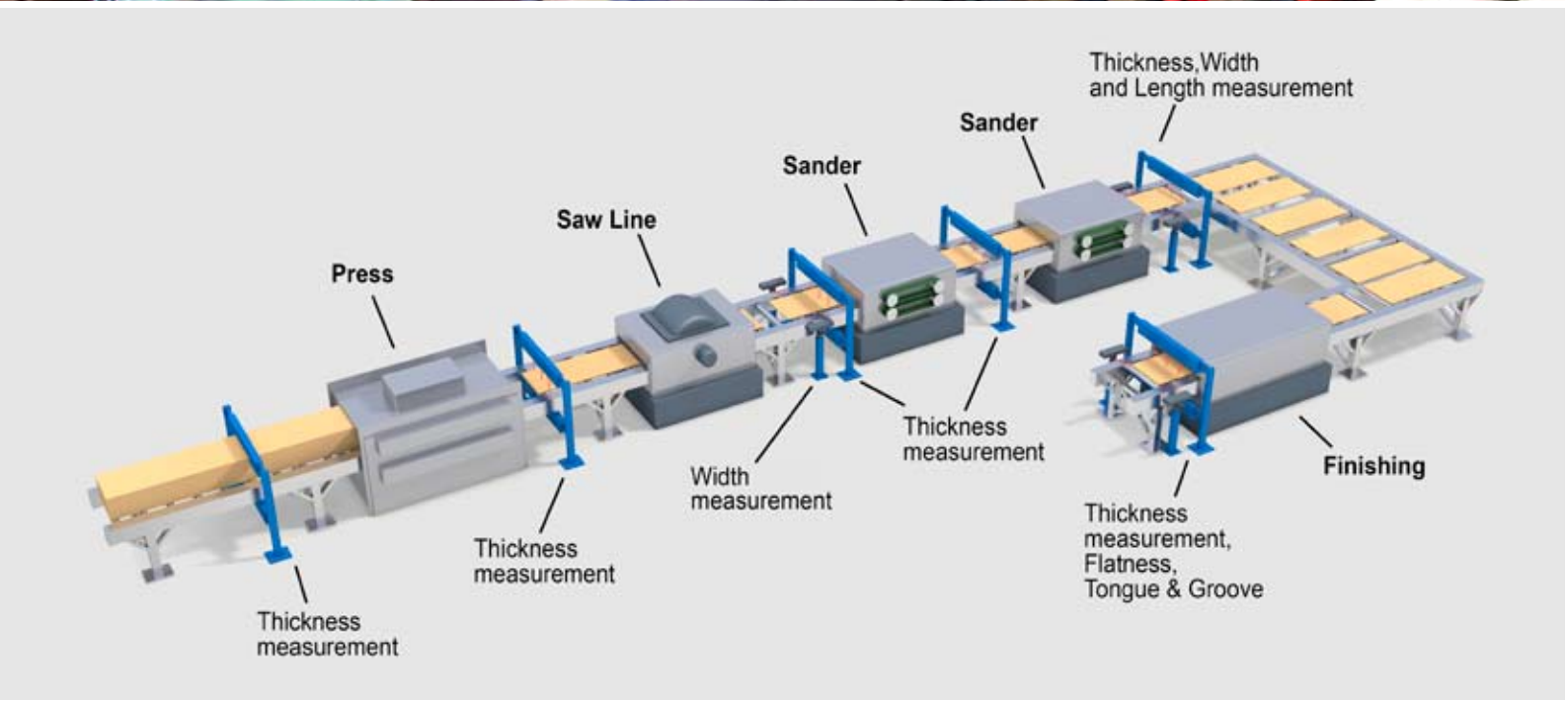

Designed for harsh conditions

LIMAB has a long experience in supplying laser measuring systems in rough production environments to ensure high accuracy and low maintenance. The PanelProfiler is equipped with a high performance air cleaning system that ensures the sensors are kept clean and cool in warm and humid applications, like after presses. The measuring frame is supplied to meet customer requirements for perfect integration into any process line.

Designed for accuracy

Achieving high accuracy is not only a question about using precision laser sensors, mechanical design considerations are equally important. The sensor mounting frames are built to minimize thermal distortion by carefully selecting materials with a low coefficient of expansion in combination with stress relieving of critical components by means of annealing. Together this results in a stable measuring system that does not need frequent recalibration. On most lines the product being measured will vibrate, knowing this we have designed a system where this does not affect the measuring accuracy. This is achieved by using a method of differential thickness measurement and high speed synchronized sampling of the sensors at a rate of 2000Hz.



Operator display from a five track system showing thickness graphs, Max, Avg, Min values along with trend charts.

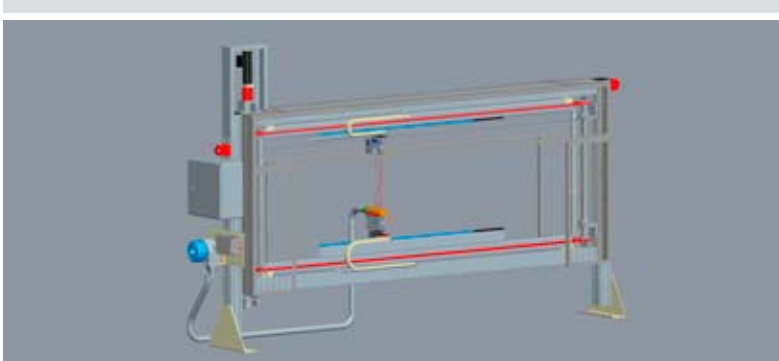
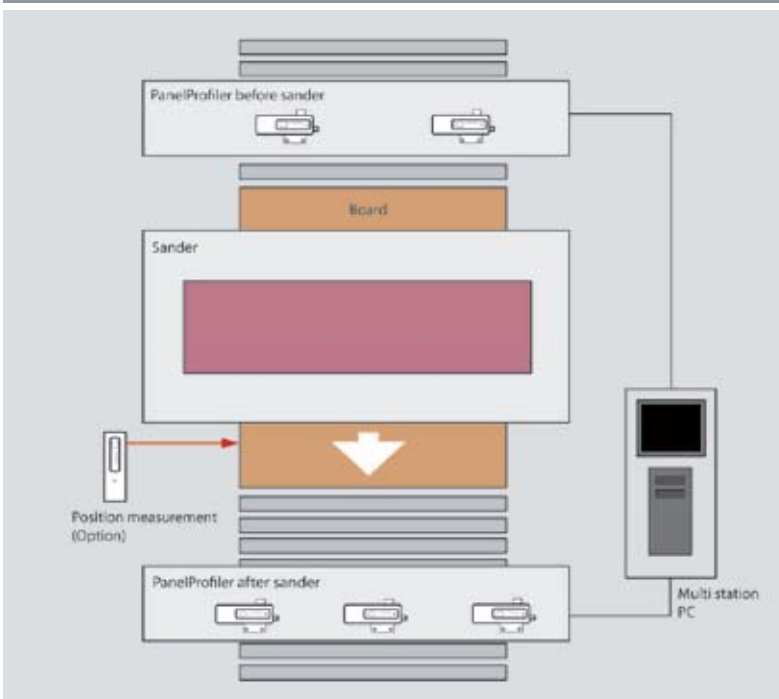

PanelProfiler – Versions for all applications

- Multi-Track** – User defined number of fixed measurement tracks (3-24). Allows measurement of smallest thickness variations and blows.
- Dual/Triple** – Multiple measurement stations before/between/after sander(s) in one system.
- Width adjustable** – Automatically adjust outer sensors pairs to panel edges.
- Traversing** – Constantly scans giving complete panel cross section profile.
- Single track** – System for measuring at a single position on the panel.

PanelProfiler

High accuracy – low maintenance costs

PanelProfiler is an in-process non-contact thickness profile measurement system. Having good control of panel thickness is essential during the manufacturing process. The PanelProfiler provides all the tools necessary to ensure that this can be achieved with minimum effort. The system will alert operators immediately if the process is starting to drift out of control improving product quality and eliminating customer rejects. This powerful process monitoring system will also increase the production yield and save both material and energy.

The PanelProfiler uses the latest laser technology to measure using a non contact method. Providing very fast sampling rate of 2000 Hz and high resolution of 0.01mm (0.4 thou). This method has been proved to be more reliable and less costly to maintain than older technologies based on contact measuring rollers. In addition there is the benefit of no product marking or compression. The laser sensors are installed in our unique and temperature stable mounting frame that requires little maintenance. The sensors only need to be cleaned periodically. Being non-contact there is no need for frequent calibration even on high speed and continuous lines. The laser technique ensures no blind spots with the full panel measurement edge to edge.

The easy to use Windows based system software has an extensive set of functions. Real time panel thickness and flatness graphs in 2D and 3D for every panel, on screen alarm indications, trends, product library and user database. In addition production statistics including Cp/Cpk are compiled and are displayed or printed on request.

The system has over the years proved its capacity in many types of panel production facilities including numerous presses, both single and multi-opening types, after sanders and in other finishing lines.



Applications

PanelProfiler is a high accuracy in-process non contact thickness measuring system. Providing high accuracy on soft or hard materials whether thin or thick.

- Typical installations at:
- Particleboard
 - MDF
 - OSB
 - Plywood
 - Veneer
 - Hardboard
 - Lightweight panels
 - Fibreboard
 - Laminates
 - Rigid foam insulation

Technical specifications

PanelProfiler

| | |
|---|---|
| Measurement range (Other ranges on request) | 0,1-200mm (0,004-7,9") |
| Accuracy | ±0,03mm (±1 thou) ±2σ |
| Resolution | 0,01mm (0,4 thou) |
| Sampling rate | 2000Hz |
| Operating temperature (Increased temperature range possible) | 0-40°C (32-104 °F) |
| Laser sensor, PreciCura SR: (Larger sensors, PreciCura MR, on request) | |
| Size | 162x108x42mm (6,28x4,25x1,65") |
| Power | <1mW |
| Wavelength | 670nm |
| Laser class (IEC825) | 2 |
| Protection class | IP65, NEMA 4X |
| PC, (subject to new technology upgrades): | |
| Operating system | Windows 7 |
| Processor | Core 15 |
| Working memory | 8GB |
| Hard disc | 2x250GB, RAID 1 |
| Screen | 21,5" Flat screen |
| Interfaces | TCP/IP, RS232C, Digital I/O |
| CAN-USB Converter | |
| Digital I/O module | XION 4 channels, expandable |
| Encoder | Incremental, CAN-Bus |
| PC cabinet | |
| Size | 2000x600x600mm (78,7"x24"x24") |
| Protection class | IP 54 |
| Sensor mounting frame | |
| Size (Customer specific) | |
| Height | No limit with leg extensions |
| Width | ≤4000mm (157") without loss of accuracy |
| Length | <300mm (12") |
| Installation | Floor mounted |



We reserve the right to introduce modifications without prior notice.



LIMAB has since its formation in 1979 been dedicated to on-line dimensional measurement in various types of industries. Today we are the market leader in non-contact thickness measurement of wood based panels with more than 100 systems installed worldwide. Design, production and assembly of both laser sensors and complete systems are made in house, backed up by an international service and sales organisation.



LIMAB North America Inc.
9301 Monroe Road, Suite B
Charlotte, NC 28270
USA
Tel: +1 704 321 0760
www.limab.com

LIMAB Oy
Henry Fordin Katu 5K
FIN 00150 Helsinki
Finland
Tel: +358 (0)9 478 03668
www.limab.fi

LIMAB GmbH
Mitterlangstr. 28
D-82178 Puchheim
Germany
Tel: +49 (0)89 840 58320
www.limab.de

LIMAB UK Ltd
Unit 3L Westpark 26
Wellington
Somerset, TA21 9AD UK
Tel: +44 (0)1823 668633
www.limab.co.uk

LIMAB®
CONTROL BY MEASUREMENT

Almedalsvägen 15
SE-412 63 Gothenburg
Sweden
Phone +46 (0)31 - 58 44 00
sales@limab.se - www.limab.com