

The Clarkson KGD wafer style slurry knife gate valve offers value and high performance in a compact package.

#### Features

- Patented, field replaceable elastomer sleeves available in a wide range of elastomers to meet varied applications.
- Dynamic self-adjusting secondary seal.
- Long lasting lubrication.
- No metal parts in contact with the flowing slurry.
- Unobstructed flow eliminates turbulence, minimizes pressure drop across valve.
- 100% Isolation; bubble-tight shut-off results in absolutely zero downstream leakage.
- Double-seated design provides bi-directional flow and shut-off.
- No seat cavity where solids can collect and prevent full gate closure.
- No gate or stem packing is required, eliminating packing leakage and maintenance.
- Adaptable frame (yoke) design featuring a top-removal stem nut, can be field modified to an air cylinder or bevel gear in the field without welding.
- Open-Closed lockout brackets standard, ready for optional factory supplied or customer supplied lockout pins.



#### General applications

- Mining
- Power
- Pulp and paper
- Alumina
- Chemical
- Cement

#### Technical data

Size range	: DN50 thru DN400 rated to 10 bar
	: DN450 thru DN600 rated to 6.2 bar
Sleeve	: Gum rubber standard
Temperatures	: Standard sleeve rated to 70°C, up to 150°C with proper elastomer selection

# Clarkson KGD Wafer Style Slurry Knife Gate Valve

## DN50 thru DN600

### How the KGD sleeves work

Matching sleeves are placed in the KGD valve housing to seal against the gate when the valve is closed and seal against each other when the valve is open. This tight seal contains the internal line pressure, precluding direct pressure against the secondary seal. As the gate moves from open to closed position, it separates the facing sleeves. The unique KGD sleeve assembly provides positive sealing action when the valve gate is closed and when the gate is open; the sleeves provide an unobstructed port and protect metal parts from the flowing slurry.

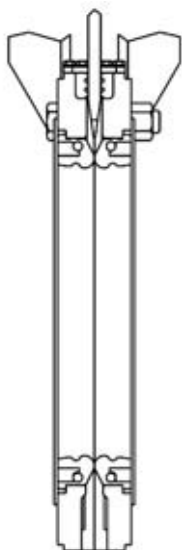

#### Open position:

- Gate positioned above seals
- Tight fit between sleeves contains internal pressure
- Metal parts not in contact with slurry
- Unobstructed port area eliminates turbulence, minimizes pressure drop across valve
- No seat cavity where solids can collect and prevent full gate closure

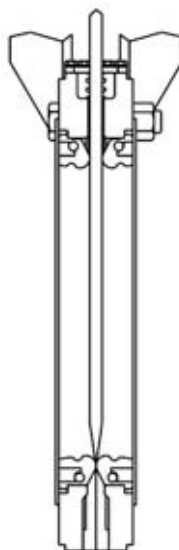

#### Closed position:

- Gate travels completely through sleeves to provide blind flange shutoff and expel solids
- 100% Isolation-bubble tight shut-off results in absolutely zero downstream leakage
- Double-seated design provides bi-directional flow and shut-off
- Tight fit between sleeves and gate contains internal pressure
- Controlled stroke prevents gate from penetrating too far, minimizing stress on sleeve

### Secondary seal

The one-piece, self-adjusting, molded elastomer secondary seal eliminates any leakage between the knife gate and top of the valve body in any orientation. The seal also prevents any outside contaminants from getting inside the valve. It is dynamically self-adjusting, eliminating the need for continual adjustment required with conventional style packing. The secondary seal is also used to lubricate the gate as it cycles through the seal, providing smoother gate movement and longer seal life, as well as reducing the force required to actuate the gate. Silicon-based lubricant is held inside a series of rib cavities built into the seal, each time the gate passes through the seal, a small amount of the long-lasting lubricant is released. The seal is replaceable and can be changed while the valve is in the line.

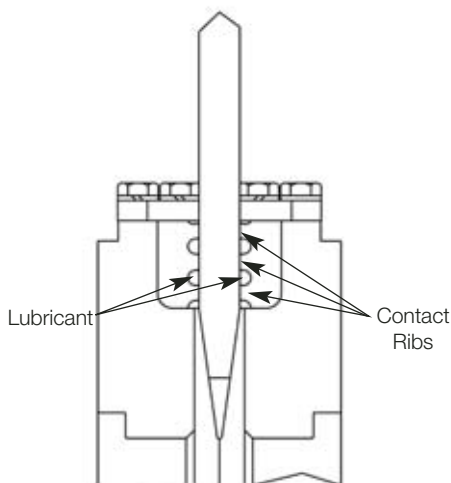

### Splash containment

The KGD valve incorporates a built-in clean-out area at the base of the valve body. The clean-out area may be enclosed by an optional, removable drain plate that is provided with ports to drain away any accumulated solids that may prevent full gate closure. Flush water can both enter and exit the clean-out area through the ports or enter through a flush port at the top of the valve body. With the drain plate in place, any solids, slurry, or flush water ejected from the valve can be handled in a controlled manner.



### Standard configuration

- Ductile iron body housings
- 316 stainless steel gate
- Universal body housing drilled and tapped to match ANSI B16.5 Class 150 companion flanges
- High tear strength gum rubber sleeves with integral support rings
- Gum rubber secondary seal

### Optional

- Various gate materials
  - 316L SS
  - 317L MN
  - 17-4 PH
  - Hastelloy® C-276
  - Feralium 255
- 316 SS body housing (DN100 thru DN300)
- Sleeves (see page 3)
- Drain plate
- Actuators (see page 4)
- Stem covers
- Control accessories
- Metric flange drilling

**Available sleeve materials**

**Gum Rubber**

This category includes all natural gum elastomers, both filled and unfilled and synthetic Polyisoprene. Has high tensile strength, superior resistance to tear and abrasion and good flexibility at low temperatures. Maximum continuous operating temperature 70°C.

**EPDM-HTP**

Advantages, excellent resistance to heat, ozone and sunlight, very good flexibility at low temperature, good resistance to alkalis, acids, and oxygenated solvents and superior resistance to water and steam. Limitations, poor resistance to oil, gasoline, and hydrocarbon based solvents. Maximum continuous operating temperature 150°C.

**Nitrile and Nitrile-HTP**

Advantages, very good resistance to oil, gasoline, alkalis and acids. Good resistance to hydrocarbon based solvents. Limitations, inferior resistance to ozone and oxygenated solvents. Maximum continuous operating temperature 107°C for HTP and 93°C for standard Nitrile.

**Hypalon**

Advantages, good low-temp properties, good abrasion resistance, excellent resistance to alkalis and acids, moderate resistance to oil and gasoline. Limitations, poor resistance to aromatic solvents. Maximum continuous operating temperature 93°C.

**Fluoroelastomer**

Advantages, outstanding resistance to high heat, excellent resistance to oil, gasoline and hydrocarbon solvents. Very good impermeability to gases, vapor and oxygen. Limitations, poor resistance to tear and cut growth, very little resistance to oxygenated solvents. Maximum continuous operating temperature 204°C (Consult factory for temperatures higher than 204°C).

**Features**

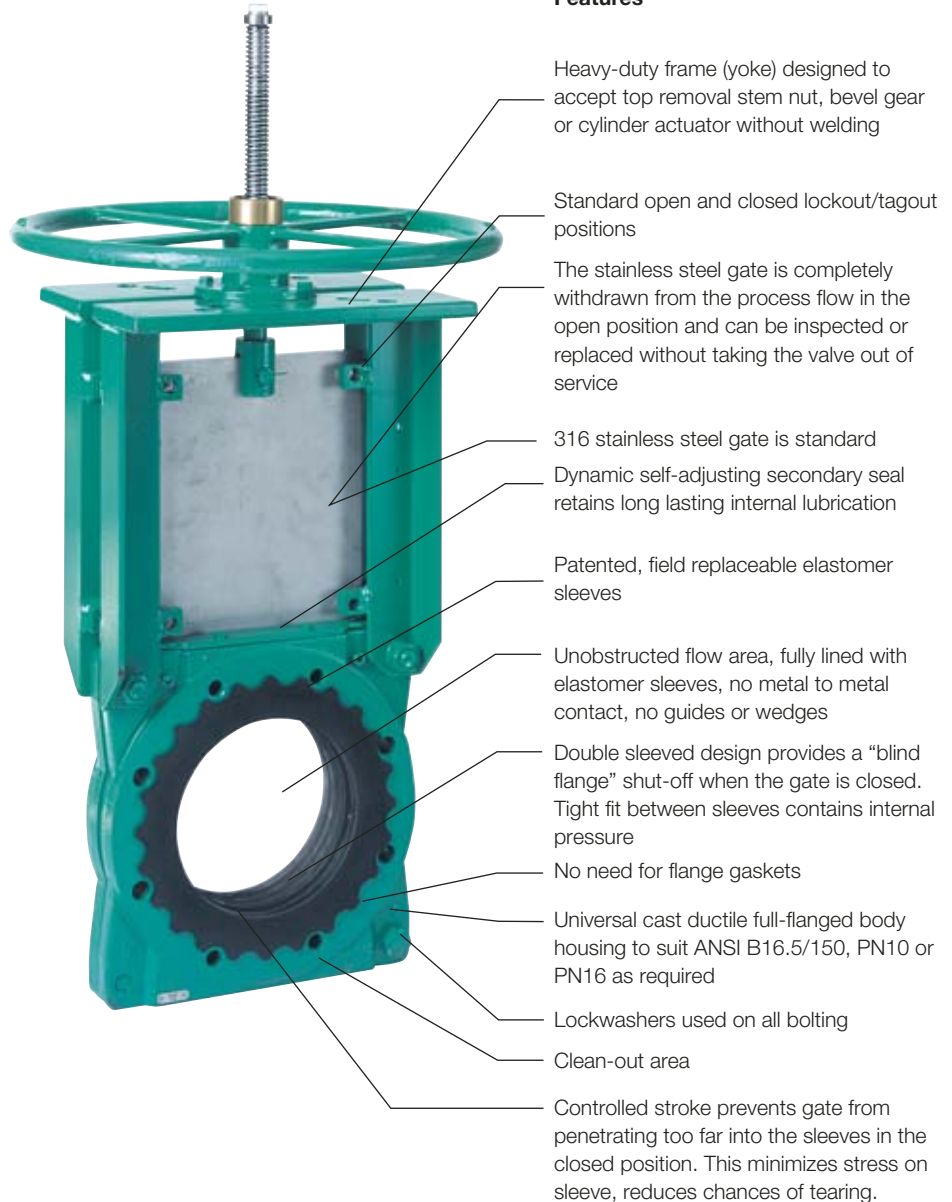

- Heavy-duty frame (yoke) designed to accept top removal stem nut, bevel gear or cylinder actuator without welding
- Standard open and closed lockout/tagout positions
- The stainless steel gate is completely withdrawn from the process flow in the open position and can be inspected or replaced without taking the valve out of service
- 316 stainless steel gate is standard
- Dynamic self-adjusting secondary seal retains long lasting internal lubrication
- Patented, field replaceable elastomer sleeves
- Unobstructed flow area, fully lined with elastomer sleeves, no metal to metal contact, no guides or wedges
- Double sleeved design provides a “blind flange” shut-off when the gate is closed. Tight fit between sleeves contains internal pressure
- No need for flange gaskets
- Universal cast ductile full-flanged body housing to suit ANSI B16.5/150, PN10 or PN16 as required
- Lockwashers used on all bolting
- Clean-out area
- Controlled stroke prevents gate from penetrating too far into the sleeves in the closed position. This minimizes stress on sleeve, reduces chances of tearing.

**Specification**

**Clarkson KGD Wafer Style Slurry Knife Gate Valve**

Wafer style, slurry knife gate valve shall be, packing less, rubber-lined, bi-directional valve suitable for a wide range of industrial applications. The full port design shall have no internal obstructions and will provide a “blind flange” shut-off when the gate is closed. The valve’s sealing surface is to be between two rubber sleeves that are compressed into the ductile iron valve housings. The sleeve will be molded with an integral stiffener ring that locates the sleeve in the valve housing and helps the sleeves resist the high shearing forces present when the gate is driven between them. Valve shall have a one-piece, molded, replaceable elastomer secondary seal to eliminate any leakage between the knife gate and top of the valve body in any orientation and prevent any outside contaminants from getting inside the valve. It shall be dynamically self-adjusting, eliminating the need for continual adjustment. The secondary seal shall retain a Silicon-based lubricant to lubricate the gate as it cycles through the seal, providing smoother gate movement and longer seal life, as well as reducing the force required to actuate the gate. The stainless steel gate shall be completely withdrawn from the process flow when in the open position, and can be inspected and replaced, if necessary, without taking the valve out of service. When the valve is in the closed position, the downstream sleeve can be replaced while the upstream portion of the valve is still holding pressure. The valve body housing to be full flanged, universal type, standard drilled and tapped to suit ANSI B16.5/150 with optional PN10 or PN16 or others, as required. Valve is equipped with a heavy steel fabricated handwheel frame (yoke) which can be converted to bevel gear or cylinder operator in the field without welding, complete with a 304 stainless steel rising stem. All nonferrous exterior surfaces shall be painted to factory standard. Specify Clarkson KGD slurry knife gate valve from Tyco Valves & Controls.

# Clarkson KGD Wafer Style Slurry Knife Gate Valve

DN50 thru DN600

## Dimensions and Weights

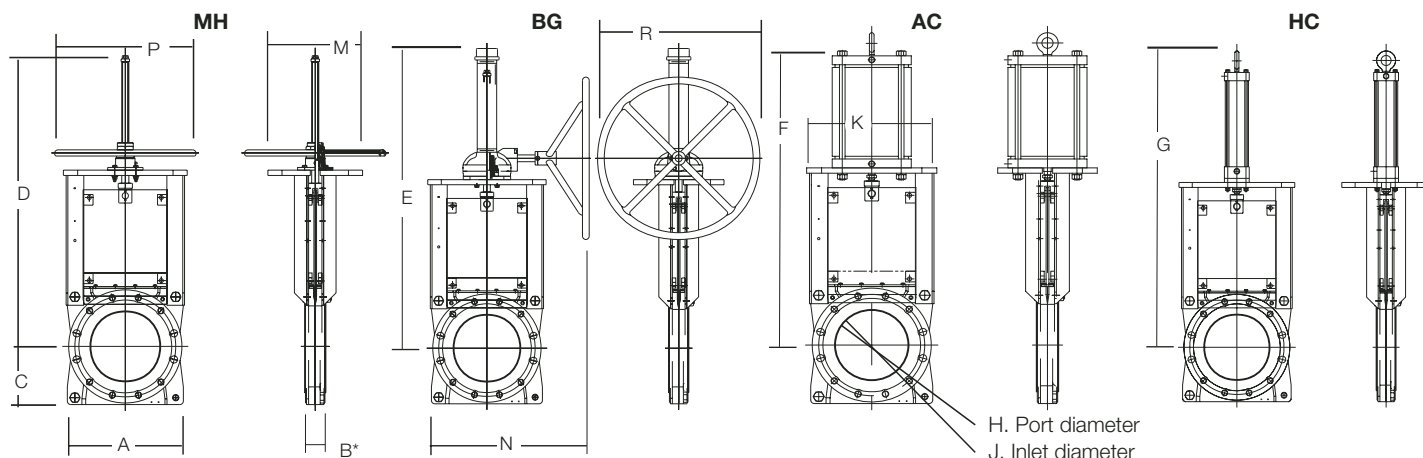

### Dimensions

Valve Size	A	B <sup>1</sup> *	B <sup>2</sup> **	C	D	E	F	G	H	J	K	L	N	P	R
50	175,3	57,2	54,1	101,6	486,9	563,4	540,8	559,8	47,0	50,8	190,5	133,4	384,3	304,8	304,8
80	203,2	62,0	57,2	124,0	567,7	611,9	627,4	640,1	71,4	76,2	222,3	162,3	400,1	304,8	304,8
100	243,8	62,0	57,2	119,1	621,0	639,1	667,3	692,7	96,8	101,6	266,7	175,5	422,4	304,8	304,8
150	279,4	68,1	63,5	146,1	748,0	838,7	803,4	825,8	147,3	152,4	320,8	231,9	449,1	406,4	304,8
200	342,9	81,0	76,2	178,6	887,5	924,3	939,8	962,2	196,3	203,2	374,7	261,9	476,3	508,0	304,8
250	416,6	82,6	76,2	209,0	1043,2	1125,2	1115,3	1137,7	247,4	254,0	444,5	339,9	606,3	508,0	609,6
300	482,6	88,9	82,6	247,7	-	1207,0	1273,3	1289,3	297,9	304,8	517,7	341,6	738,1	-	609,6
350	533,4	88,9	82,6	273,6	-	1340,9	1369,1	1372,4	329,2	336,6	572,8	374,7	765,8	-	609,6
400	603,3	101,6	95,3	301,8	-	1435,9	1500,4	1503,7	381,0	387,4	621,5	374,7	790,2	-	609,6
450	647,7	103,1	95,5	308,1	-	1680,7	1728,5	1737,9	431,8	438,2	668,5	431,8	768,6	-	609,6
500	711,2	130,3	120,9	368,3	-	1823,5	1878,8	1882,1	483,4	489,0	712,7	479,6	790,7	-	609,6
600	838,2	131,8	120,9	419,1	-	2162,3	2216,2	2235,2	589,5	595,6	889,0	479,6	878,8	-	609,6

Universal flanges drilled and tapped to ANSI B 16.5/150 or PN10 and PN16 or others, as required.

B<sup>1</sup> = minimum dimension required for installation.

B<sup>2</sup> = installed face-to-face.

### Actuation

Note: Not all actuators shown are available on all valve sizes.



MH Manual Handwheel



BG Manual Bevel Gear



AC Air Cylinder



HC Hydraulic Cylinder



EM Electro-mechanical



RA-Ratchet

### Weights

Size	MH and BG	AC	HC
50	20	28	24
80	25	38	31
100	34	42	39
150	40	65	44
200	64	86	66
250	89	147	102
300	169	224	143
350	199	297	171
400	238	334	243
450	258	381	288
500	331	528	341
600	476	732	522