



Manual polymer preparation unit

This station is used for preparing polymer for further injection into sludge for dewatering operation on screw press (MP-DW series). Station consists of tank, clean water inlet ball valve, drainage ball valve, shaft with gearmotor and blades, motor start/stop switch.

Station is manual, typical preparation sequence is following:

- Filling by clean water
- Dosing of exact amount of powder polymer or liquid concentrate – by operator
- Mixing (time can be various for each type of polymer)
- Polymer is ready for injection to dewatering screw press

Station can be equipped with water level probes or level switch for low-polymer indication and automated stop of dewatering machine.

Specification

- Motor: **MOTIVE**, D80A-2, 0.75 KW, 3x400V/230V (Y/D), 2950 [min^{-1}]
- Gearbox: **MOTIVE**, BOX50/7.5, ratio 7.5, output 393 [min^{-1}]
- Water inlet valve: G 3/4"
- Drainage valve: G 5/4"

Type	Material	Volume [l]	D [mm]	L [mm]	Weight [kg]	Electric power [kW]	Mixing rings
MSP300	Polypropylene	300	800	600	35	0.75	1 (s2)
MSP600	Polypropylene	600	800	1200	50	0.75	1 (s2)
MSP1100	Polypropylene	1100	1100	1200	70	0.75	2 (s2)
MSP1400	Polypropylene	1400	1200	1300	85	0.75	2 (s2)
MSP2600	Polypropylene	2600	1500	1500	125	0.75	2 (s3)

MIVALT

Dimensions

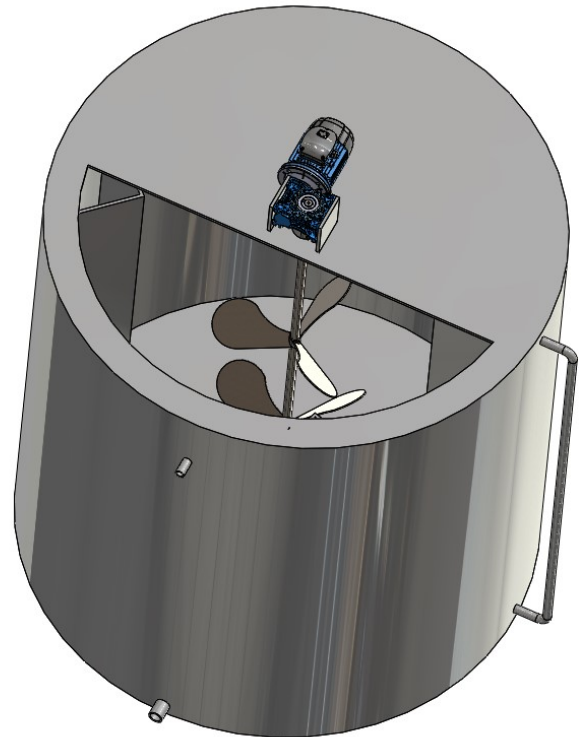
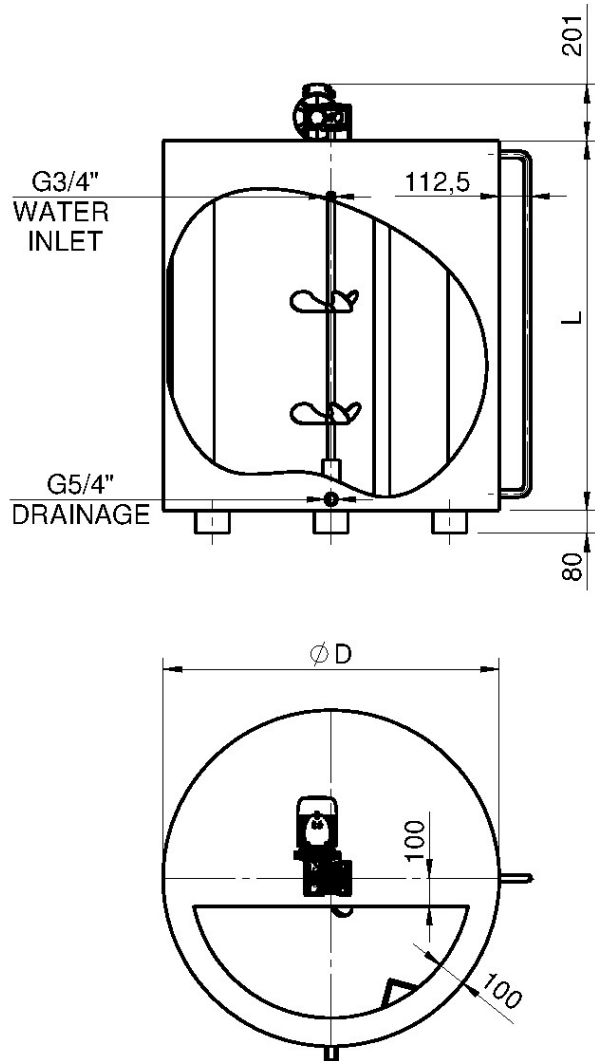

Made in the Czech republic.

Manufacturer:

MIVALT s.r.o.
Hlinky 34
Brno, 603 00
Czech republic

www.mivalt.eu